

Go Vertical with Roller Carousels

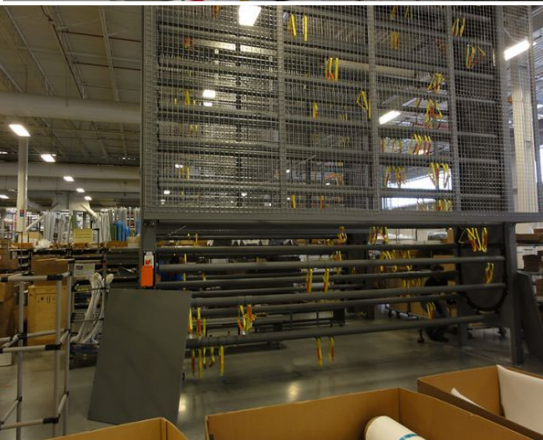

The Roller Carousel is a top-tier storage and display system for rolls of different dimensions, saving floor space by storing them vertically. It enhances warehouse automation, boosting productivity and safety.

Height: 9' to 23' 10"

Width: 6' and up to 20' (maximum)

Weight capacity of carousel: 16,000 lb gross | 13,000 net with product (varies with application)

- **User-Friendly:** Simple design, easy operation, and intuitive controls for quick setup and use.
- **Effortless Material Handling:** Eliminates the need for manual lifting, bending of materials.



Shelving



Tire

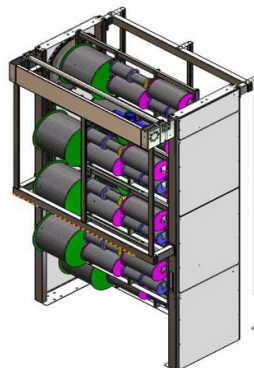

Spools

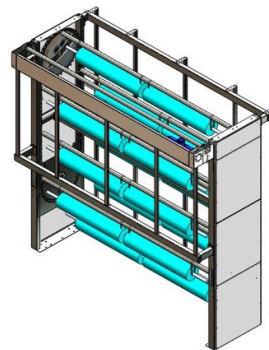

Print Cylinder

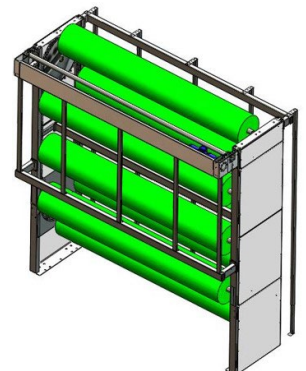

Rolls

American Specialty

800-466-9561
www.americanspecialty.biz