

# Go Vertical with Shelving Carousels



The Shelving Carousel is an automated vertical storage system for heavy items, improving efficiency and safety by bringing items to the operator.

It's customizable for unique needs and enhances warehouse automation.

- *Optimize Space: Maximize your current workspace with vertical tray storage carousels, avoiding the need for expensive expansion.*
- *Safety Assurance: Enhance overall safety and increase ergonomic workplace practices.*
- *Durability: Expect long-term performance and toughness from vertical shelving carousel solutions.*
- *Affordable Productivity: Cost-effective installation leads to enhanced productivity, offering a strong return on investment (ROI).*

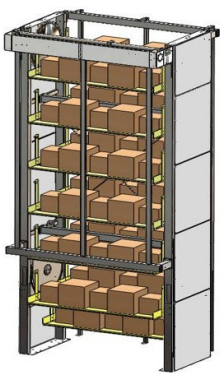

Shelving



Tire

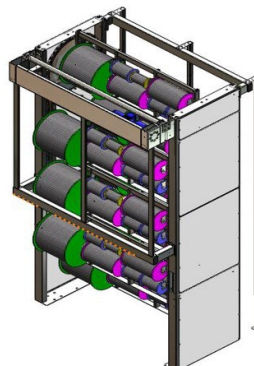

Spools

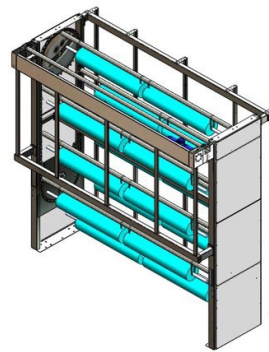

Print Cylinder

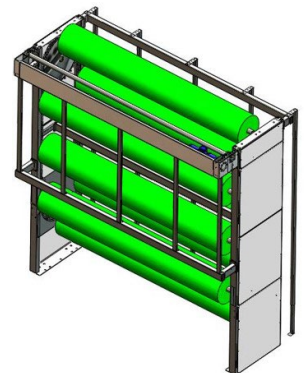

Rolls

## American Specialty

800-466-9561  
[www.americanspecialty.biz](http://www.americanspecialty.biz)